

THIS DRAWING IS UNPUBLISHED. RELEASED FOR PUBLICATION .19  
 © COPYRIGHT 19 BY AMP INCORPORATED. ALL INTERNATIONAL RIGHTS RESERVED.

|     |      |   |   |           |     |                      |         |       |
|-----|------|---|---|-----------|-----|----------------------|---------|-------|
| LOC | DIST | P | F | REVISIONS |     |                      |         |       |
| G   | 14   |   |   | ZONE      | LTR | DESCRIPTION          | DATE    | APPD  |
|     |      |   |   |           | F   | REV PER 0G3A-0001-03 | 06JAN03 | JR TM |

|                          |                       |                       |
|--------------------------|-----------------------|-----------------------|
| <b>AMP</b><br>WIRE RANGE | Listed                | Certified             |
| 16-14 AWG<br>STRANDED    | 16-14 AWG<br>STRANDED | 16-14 AWG<br>STRANDED |

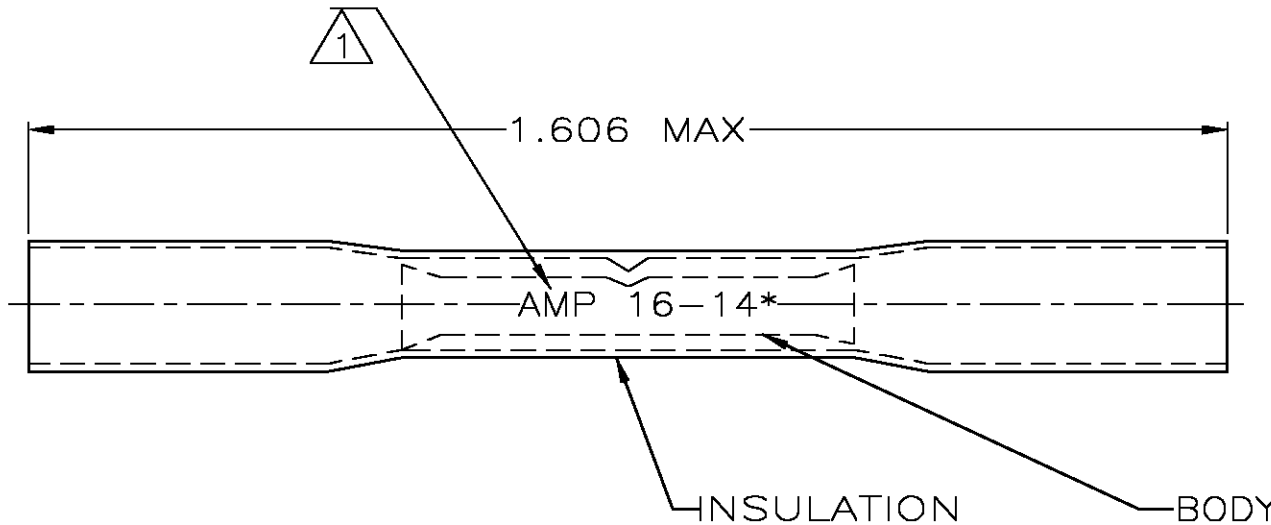

- ① STAMP AMP 16-14\* APPROX AS SHOWN
- ② WIRE INSULATION .190 MAX DIA.
- ③ NO AGENCY APPROVALS - NEITHER UL OR CSA APPROVED.

|      |               |             |
|------|---------------|-------------|
| 2500 | ON TAPE, REEL | ③ 2-55825-1 |
| 50   | LOOSE PIECE   | 8-55825-2   |
| 1000 | LOOSE PIECE   | 55825-1     |
| QTY  | PACKAGE TYPE  | PART NO     |

**AMP INCORPORATED  
 CUSTOMER SERVICE SYSTEMS**

|  |  |
|--|--|
| FOR ADDITIONAL PRODUCT INFORMATION OR COPIES OF DRAWINGS AND TECHNICAL DOCUMENTS | PRODUCT INFORMATION CENTER<br>1-800-522-6752 |
| FOR APPLICATION TOOLING INFORMATION  | TOOLING ASSISTANCE CENTER<br>1-800-722-1111  |
| FOR ORDER ENTRY  | 1-800-526-5142                               |

MAX RECOMMENDED OPERATING TEMPERATURE:  
 125° C MAX

VOLTAGE RATING:  
 600V MAX (BUILDING WIRING)  
 1000V MAX (FIXTURES & SIGNS)

CIRCULAR MIL AREA:  
 1.04-2.62mm<sup>2</sup> [2050-5180]  
 STRANDED

DO NOT SCALE PRINT. UNLESS SPECIFIED DIMENSIONS ARE IN INCHES TOLERANCES ON:  
 2 PLC DEC ± .008  
 3 PLC DEC ± -  
 ANGLES ± -

MATERIAL  
 BODY: ETP COPPER  
 INSULATION: POLYOLEFIN  
 COLOR: BLUE

FINISH  
 EDP TIN PLATED

DR 6/93  
 S S GOULDEN  
 CHK 6/93  
 R HERSEY  
 APPD 6/93  
 B BARE  
 APPD 6/93  
 M ELLIS  
 PRODUCT SPEC -  
 APPLICATION SPEC -  
 WEIGHT -

**AMP** AMP Incorporated  
 Harrisburg, PA 17105-3608

NAME  
 SPLICE, SEALABLE  
 HEAT SHRINKABLE

|       |           |            |
|-------|-----------|------------|
| SIZE  | CAGE CODE | DRAWING NO |
| B     | 00779     | C-55825    |
| SCALE | NTS       | SHEET      |
|       |           | 1 OF 1     |